

CAGE	DWG NO	900-1028-00-0	REV	1	REV	-	1
REVISIONS							
ZONE	REV.	DESCRIPTION	DATE	APPROVED			
	-	INITIAL RELEASE	8/12/18	REN			

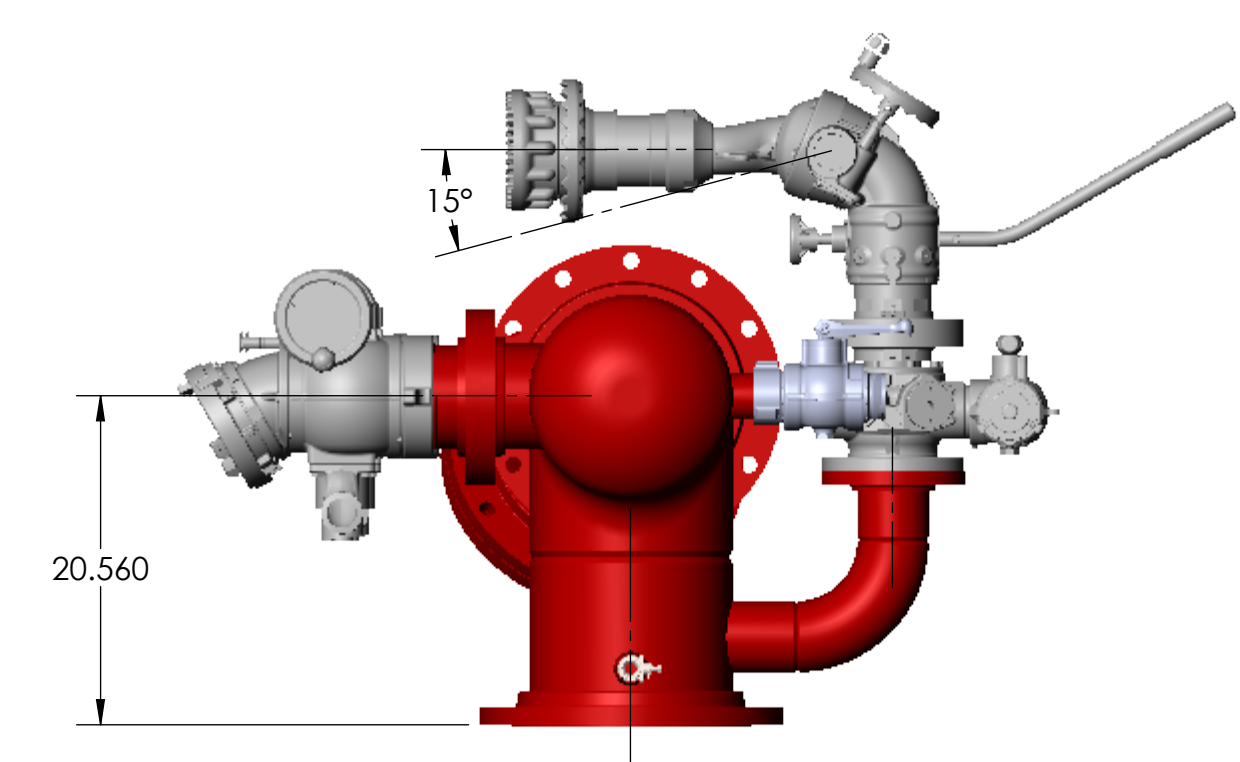
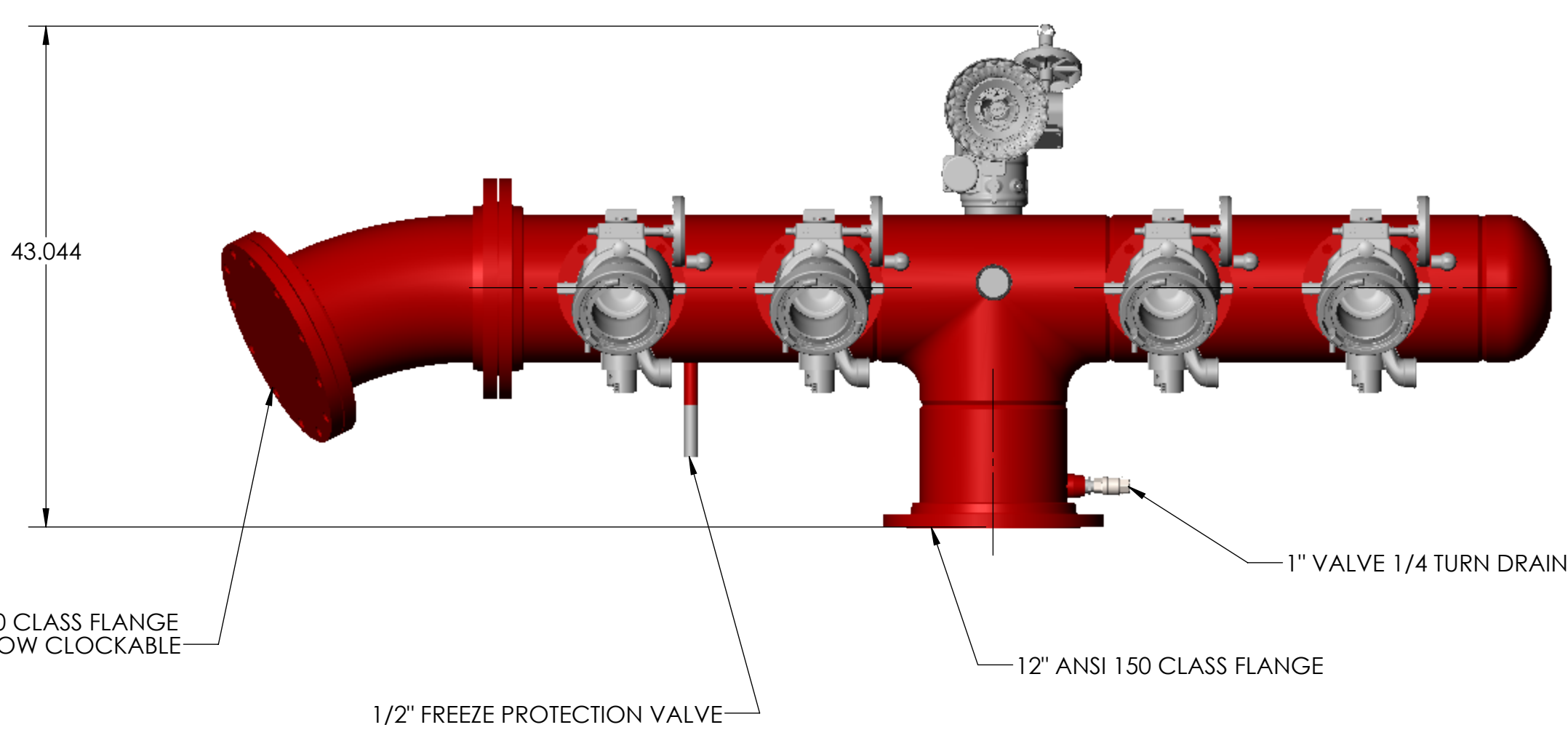
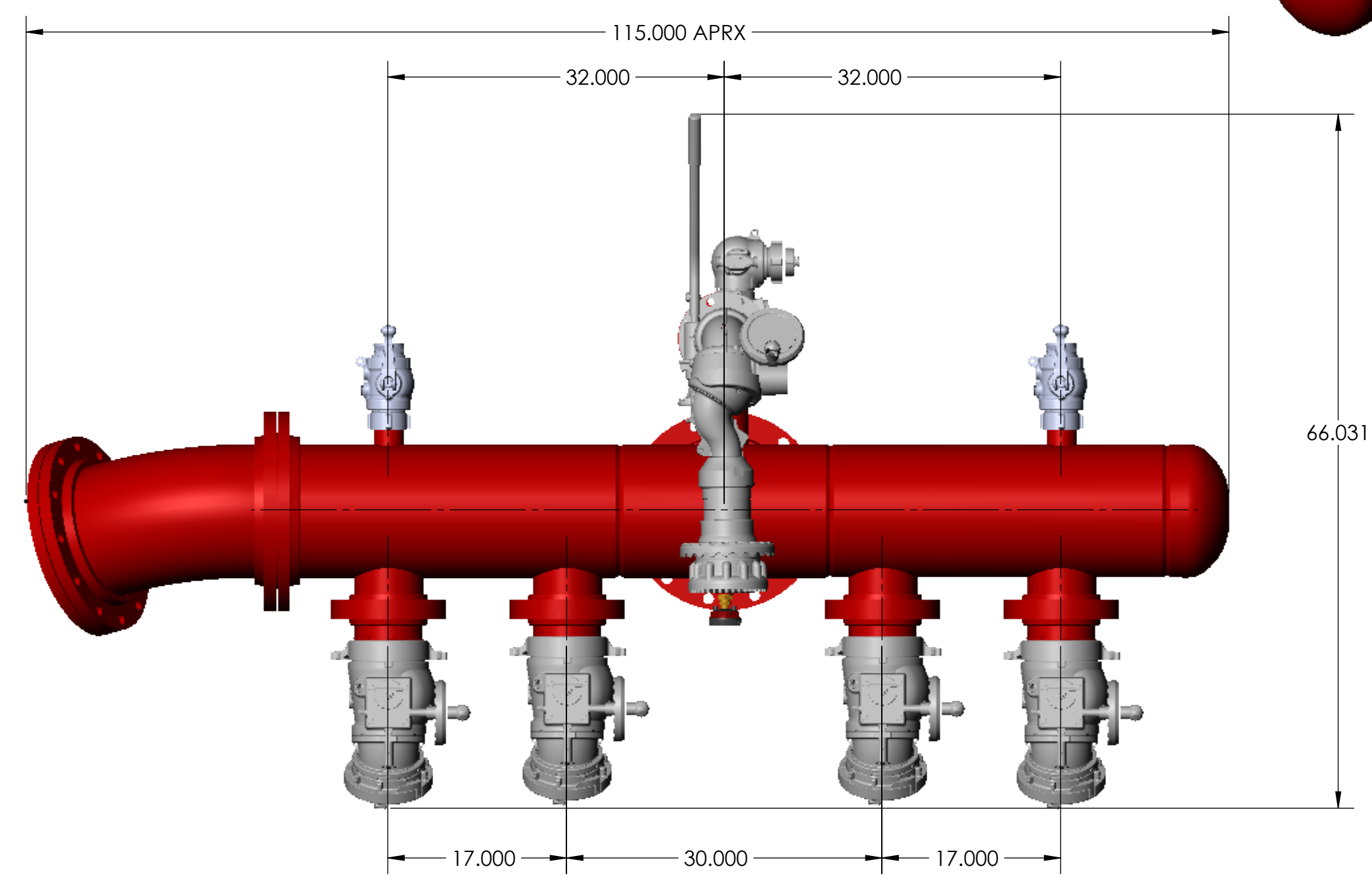
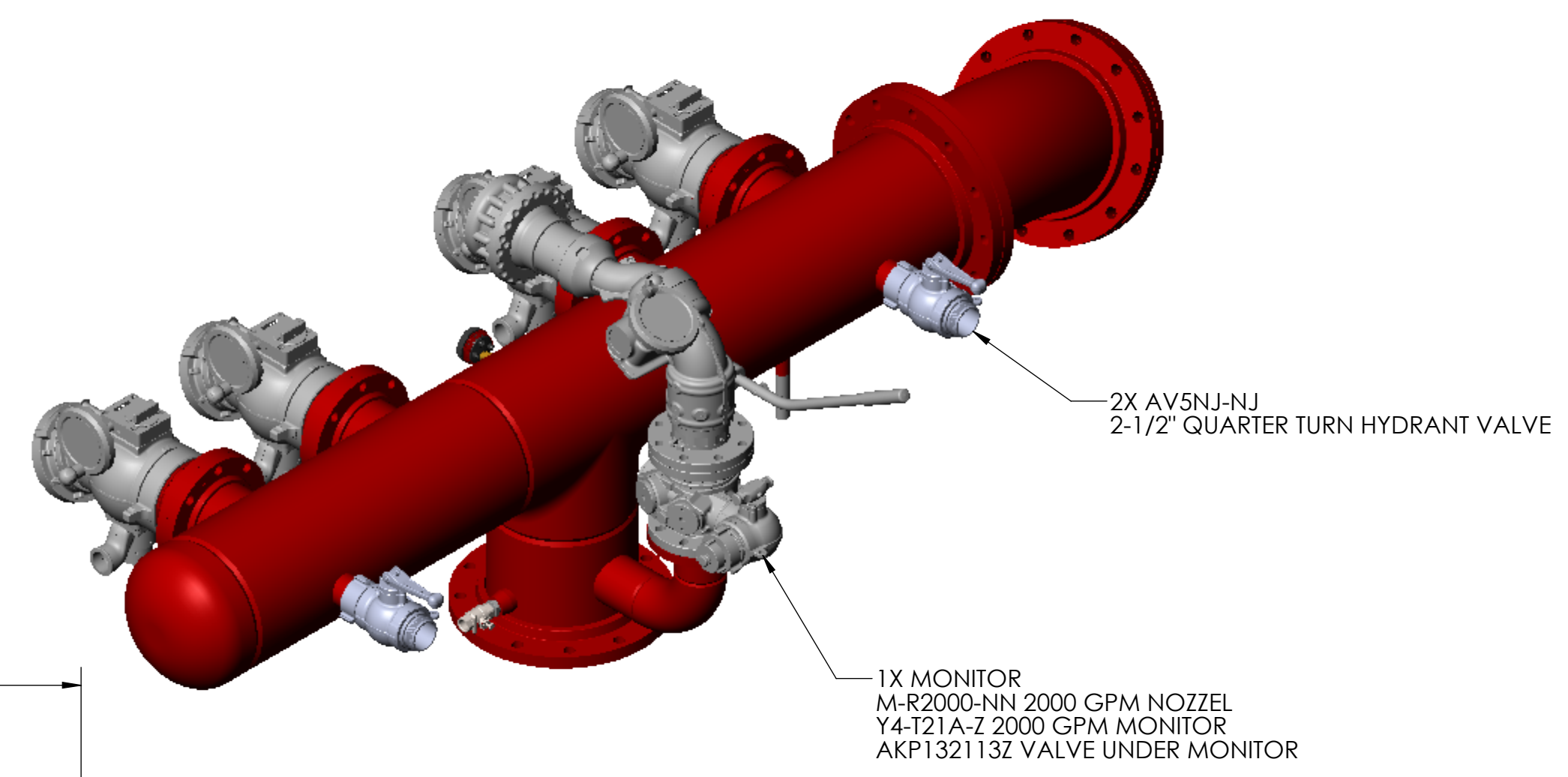
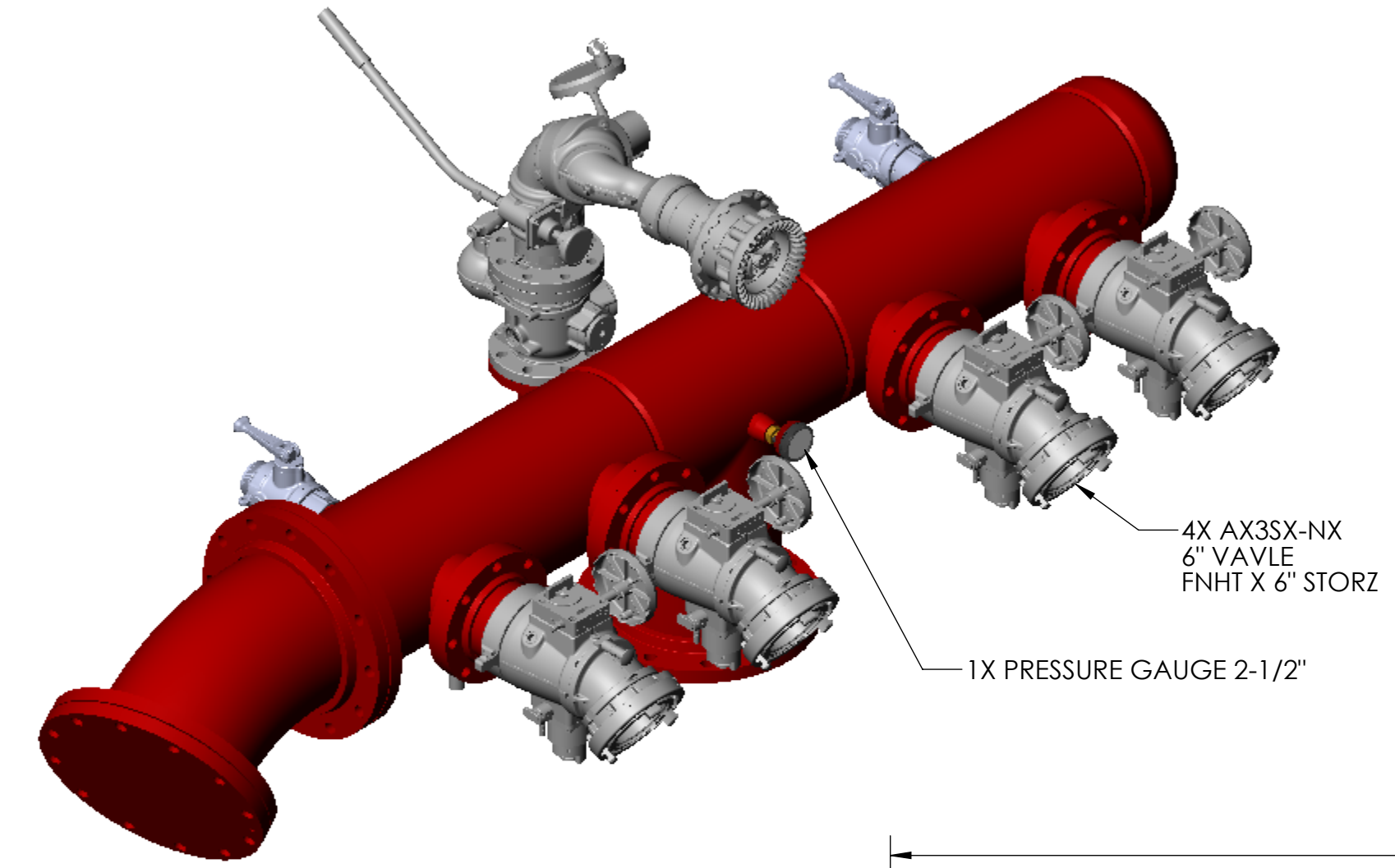

THE INFORMATION CONTAINED HEREIN IS PROPRIETARY DATA, AND IS NOT FOR DISSEMINATION OR DISCLOSURE, IN WHOLE OR IN PART, FOR ANY PURPOSE OTHER THAN THAT FOR WHICH IT IS SUBMITTED, EXCEPT AS AUTHORIZED IN WRITING BY US FIRE PUMP.

DELIVERY MUST CONFORM EXACTLY WITH DRAWING SPECIFICATIONS AND APPROVED Q.A. SAMPLES. ABSOLUTELY NO CHANGES ARE PERMITTED WITHOUT PRIOR APPROVAL BY US FIRE PUMP. THIS INCLUDES CHANGES TO: SOFTWARE, MATERIALS, INTERNAL COMPONENTS, MANUFACTURING PROCESSES.

INCH

ADDITIONAL APPROVALS	DATE																			
STRESS																				
MATERIALS & PROCESSES																				
QUALITY ASSURANCE																				
MANUFACTURING ENGINEERING																				
TREATMENT																				
UNLESS OTHERWISE SPECIFIED DIMENSIONS ARE IN INCHES. TOLERANCES ARE:										PROJECT										
DECIMALS: .XX ± 0.02 ANGLES: ± 0.5°										APPROVALS		Manifold - Hydrant, 12" Inlet, 4x6"/1x12"/2x2-1/2" Outlet, Monitor, Freeze Protection Valve								
XXX ± 0.010 SHEETMETAL DIMENSIONS: ± 0.015										DATE		1:12								
DO NOT SCALE DRAWING										DRAWN		900-1028-00-0								
MATERIAL										CHECKED		1072.550								
APPLICATION										DESIGNER		1 of 1								
THIRD ANGLE										APPROVED										
FINISH										SCALE										
										RELEASE DATE										